



MICROWAVE VS RADIO FREQUENCY HEATING

INDUSTRIAL, SCIENTIFIC AND MEDICAL (ISM) RADIO FREQUENCY (RF) BANDS

These are the center frequencies for the ISM RF bands:

Radio Frequency Heating

- 6.780 MHz; 13.560 MHz; 27.120 MHz; 40.68 MHz

Microwave Heating

- 433.92 MHz (strictly controlled in Americas)
- 915 MHz (strictly controlled in Europe)
- 2.450 MHz (most common for varied applications under 50 kW)
- 5.800 MHz; 24.125 GHz; 61.25 GHz; 122.5 GHz ; 245 GHz

Source:
https://www.ntia.doc.gov/files/ntia/publications/spectrum_wall_chart_aug2011.pdf

Full Global Listing:

- 6.765-6.795 MHz (center frequency 6.780 MHz)
- 13.553-13.567 MHz (center frequency 13.560 MHz)
- 26.957-27.283 MHz (center frequency 27.120 MHz)
- 40.66-40.70 MHz (center frequency 40.68 MHz)
- 433.05-434.79 MHz (center frequency 433.92 MHz) in Americas
- 902-928 MHz (center frequency 915 MHz) in EMEA
- 2.400-2.500 MHz (center frequency 2.450 MHz)
- 5.725-5.875 MHz (center frequency 5 800 MHz)
- 24-24.25 GHz (center frequency 24.125 GHz)
- 61-61.5 GHz (center frequency 61.25 GHz)
- 122-123 GHz (center frequency 122.5 GHz)
- 244-246 GHz (center frequency 245 GHz)

DIELECTRIC HEATING EXPLAINED

- Excluding materials which are good conductors of electricity, heat is generated when an object is subjected to an electromagnetic field. This is caused by dielectric losses.*
- These losses are the result of the polarization of ionic particles in the material (millions of times per second) due to the oscillation of the electromagnetic field.
- This rapid polarization creates molecular friction which translates into thermal energy, increasing the temperature of the material.
- Water molecules are one of the most polar in existence, and are usually more polar and therefore more “dielectrically lossy” than any other molecules found in materials containing water. As a result, they heat the fastest and most efficiently. This is why dielectric heating is excellent for drying applications.

***Dielectric loss** quantifies a **dielectric** material's inherent dissipation of electromagnetic energy (e.g. heat). It can be parameterized in terms of either the **loss** angle δ or the corresponding **loss** tangent $\tan \delta$.

DESIGN OF MW AND RF DRYERS

MICROWAVE DRYER

- A unit is made up of three parts; the generator, the waveguide, and the applicator
- The applicator for MW units is most often a multi-mode cavity where microwaves bounce around, heating the material that passes through from all directions
- The standing wave pattern in the cavity oscillates the water molecules at the frequency of the generator

RF DRYER

- A unit is made up of two parts; the generator, and the applicator with the capacitor
- The applicator for RF designs is made up of two electrodes that pass a voltage between them at the RF frequency
- The voltage oscillates at the frequency of the generator, causing the water molecules to reverse polarity

DESIGN OF MW AND RF DRYERS

MICROWAVE DRYER

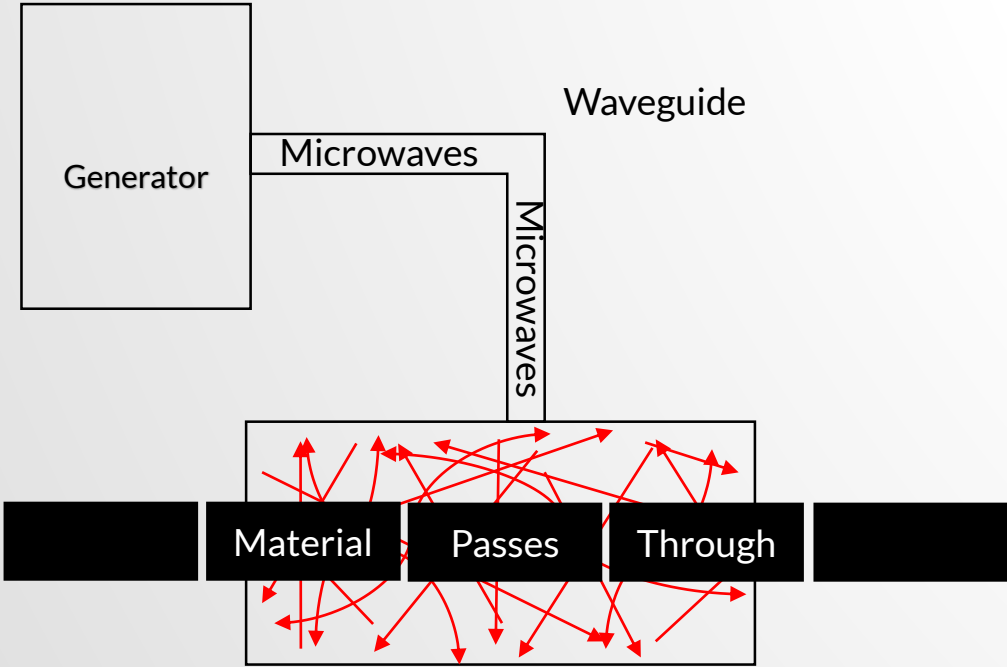

RF DRYER

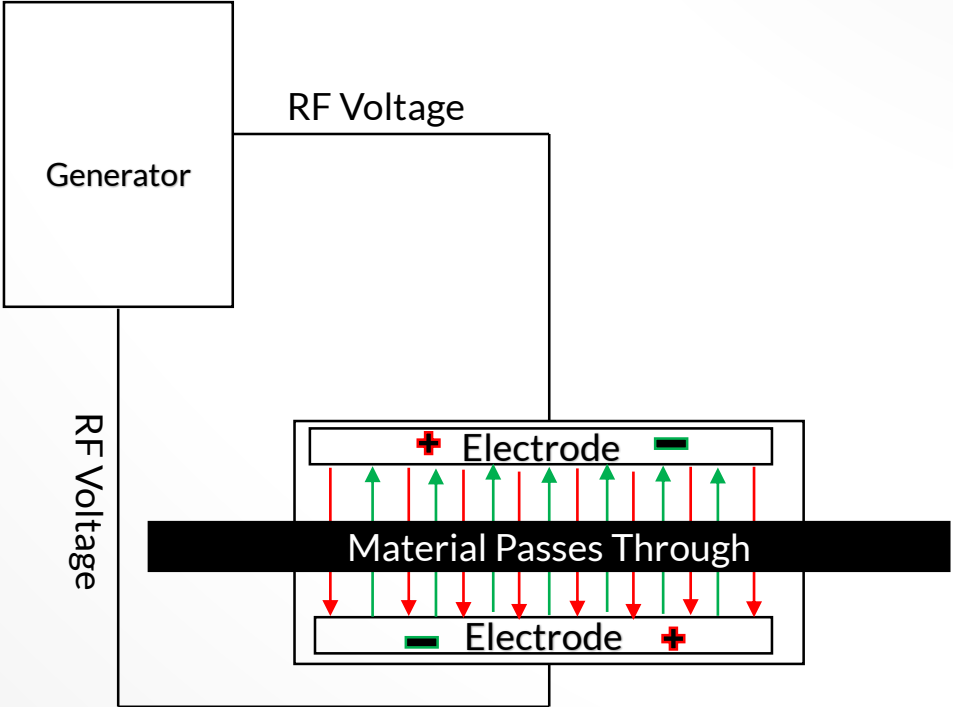

RF vs MICROWAVE DRYING AND THE COMPARATIVE ADVANTAGES

Microwave

- Single and Multi-mode heating applications
- Multi-mode operations allows for use with more varied materials
- Shorter wavelength enables higher rates of dielectric heating, increasing the electrical efficiency of the system compared to RF heating
- Can handle multi-use scenarios with different products utilizing multi-mode cavity design

Radio Frequency

- Requires very uniform bed of material for efficient operation, which is why it is often used in textile drying and baking applications
- Larger in size than microwave dryers, because the technology requires large capacitors
- Heats slower since the dielectric heating occurs at low frequencies

RF vs MICROWAVE DRYING COMMON USE CASES

Microwave

- Tempering of beef, vegetables, and high power (>150 kW) drying
- 915 Mhz, and 2,450 Mhz
- Single and Multi-mode heating applications
- Multi-mode operations allows for use with more varied materials
- Shorter wavelength enables higher rates of dielectric heating, increasing the electrical efficiency of the system compared to RF heating.

Radio Frequency

- Textile and grain drying, post-baking treatments, some tempering
- 7 MHz, 14 MHz, 27 MHz (most common) and 40 MHz
- Design lends itself to low, consistent beds of material

THANK YOU

Ferrite Microwave Technologies, LLC
165 Ledge Street, Nashua, NH 03060

TEL: +1 800-854-1466 | +1 603-881-5234
FAX: +1 603-881-5406

www.ferriteinc.com

